

# AVERY DENNISON MARKETING SPECIFICATION

## HISTORY

REV.	DATE	DESCRIPTION
A	3/1/07	RELEASE TO PRODUCTION
B	3/04/08	INCREASE CAPACITY
C	11/18/16	UPDATED FORMAT; ADDED FLAMMABILITY SPEC AND SPECIAL CHAR., INSERTION AND EXTRACTION SPEC

THE SUBJECT MATTER DISCLOSED HEREIN EMBODIES PROPRIETARY INFORMATION WHICH IS THE CONFIDENTIAL PROPERTY OF THE AVERY DENNISON CO. NONE OF WHICH SHALL BE COPIED, REPRODUCED, DISCLOSED TO OTHERS, PUBLISHED OR USED IN WHOLE OR IN PART, FOR ANY PURPOSE OTHER THAN THAT FOR WHICH IT IS BEING MADE AVAILABLE WITHOUT THE EXPRESS ADVANCE WRITTEN PERMISSION OF A DULY AUTHORIZED AGENT OF THE COMPANY. THIS DOCUMENT IS THE PROPERTY OF THE AVERY DENNISON CO. AND IS TO BE RETURNED TO THE COMPANY ON DEMAND.

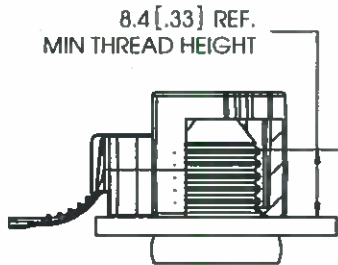

**ASSEMBLED VIEW**

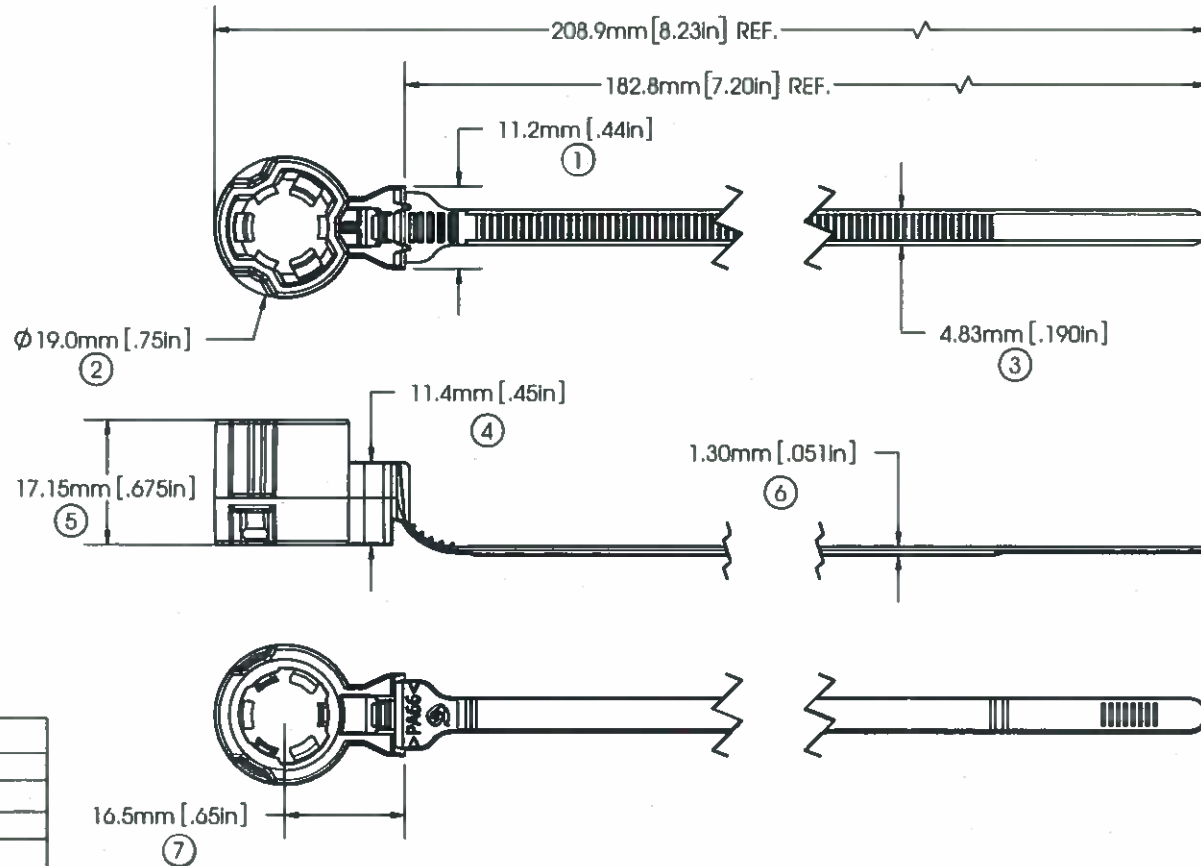

NOTES:  
1. SPECIAL CHARACTERISTICS ARE NOTED BY A TRIANGLE ( Δ )

8	Δ FLAMMABILITY RATING:	HB RATED PER FMVSS302
9	Δ TENSILE STRENGTH:	50 LBF / 22.7 KGf MIN.
	INSERTION FORCE:	10 LBF / 44.5N MAX.
	EXTRACTION FORCE:	35 LBF / 155.7N MIN.
	MOUNTING:	M12 THREADED STUD, SEE ASSEMBLED VIEW FOR ADDITIONAL REQUIREMENTS
	OPERATING TEMP RANGE:	-40°F (-40°C) TO 239°F (115°C) CONTINUOUS AND 257°F (125°C) AT MAXIMUM EXPOSURE
	WEIGHT:	3.5g
	BUNDLE DIAMETER:	Ø 1.6mm TO Ø 44.5mm
	TOOL:	TOOL HAND ADJUSTABLE, FOR PLASTIC TIE DOWN STRAP, AVERY DENNISON PART NO. 12001-0
	TOOL TENSION SETTING:	6 - 8
	PACKAGING:	500/BAG, 10 BAGS/MASTER

APPROVALS: ENG. APPR. *Darin Padden 11/18/16*  
Q.A. APPR. *Cynthia Challenor 11/18/16*

SPECIFIC TOLERANCES ARE:  
.XX ± .03 INCHES .X ± .7 mm  
.XXX ± .010 INCHES .XX ± .25 mm  
ANGULAR: ± 2°

MATERIAL NYLON 6/6, IMPACT MODIFIED, HEAT STABILIZED  
COLOR BLACK

**AVERY DENNISON**  
FASTENER DIVISION  
FITCHBURG, MA 01420 U.S.A.  
TEL. 1-800-225-6913  
FAX. 978-353-8157

DESCRIPTION M12 WELD STUD TIE  
STOCK NO. 20116-0  
REV. C